

HEIGHT ADJUSTABLE BASE

PRO Assembly - Install Guide

Premier Handset



Checklist

Please check all of the components shown in the component checklist. If any of the components are missing or damaged, contact your point of purchase for a replacement.

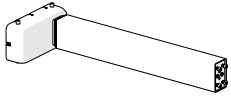

A (x2)
Leg Column

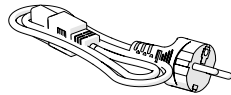

E (x1)
Power Cord



F (x1)
Connection Cable

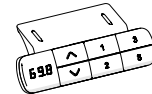

G (x1)
Handset

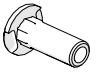

H (x4)
Dowel pin

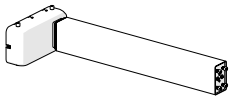

A (x2)
Leg Column

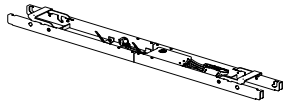

B (x1)
Top Frame, Control box



C (x2)
End Pipe (T-style shown)

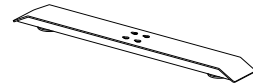

D (x2)
Foot (T-style shown)

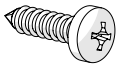

I (x8)
ST4.8x19

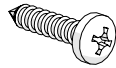

J (x2)
ST3.5x16



K (x2)
ST3.5x16

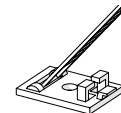

L (x2)
Cable Clip

Installation

Step 1

Insert End Pipes **C** into Top Frame **B** ends.

Loosen the 8 grub screws on the Top Frame and extend to suit the top size with the desired overhang.

Tighten grub screws, ensuring all are gripping with the beam insert.

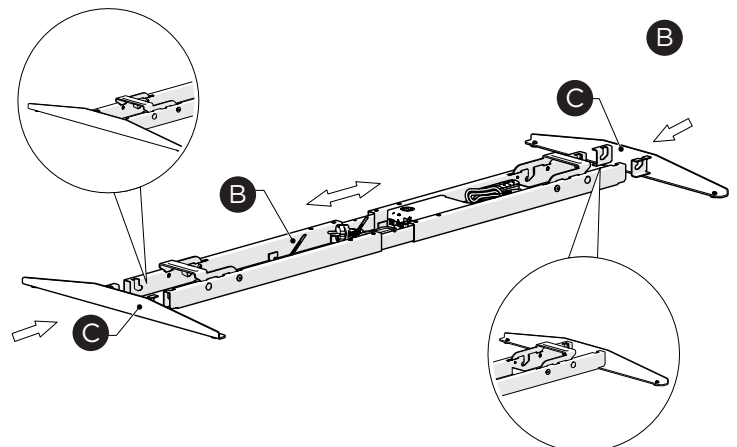

Step 2

Lift quick assembly brackets on Top Frame **B**, and guide 2 Leg Column **A** into the mounting slots.

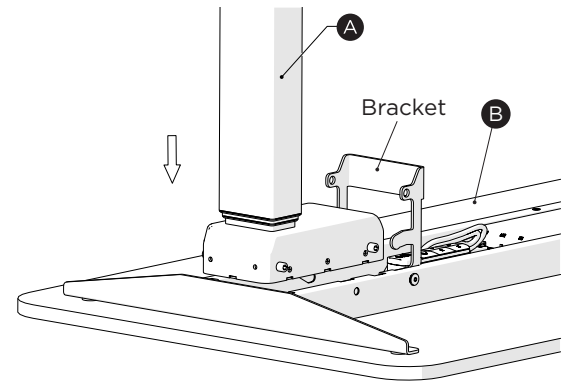

Step 3

Lower the quick assembly brackets on Top Frame **B** to lock the Leg Column **A** and End Pipe **C** into place. Use your foot to push the bracket completely flat, as shown.

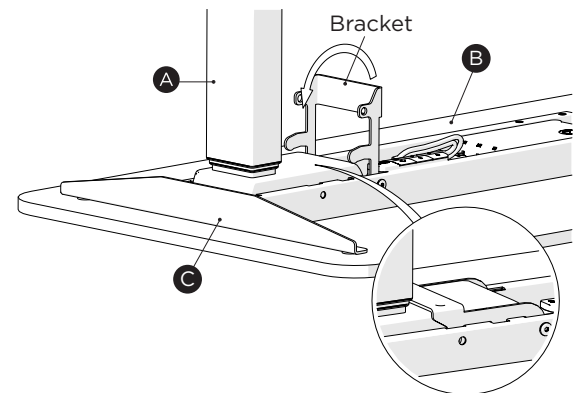

Step 4

Insert 4 Plastic Dowel Pin **H** into Top frame to securely lock quick assembly brackets, as shown.

Dowels are difficult to remove once installed.

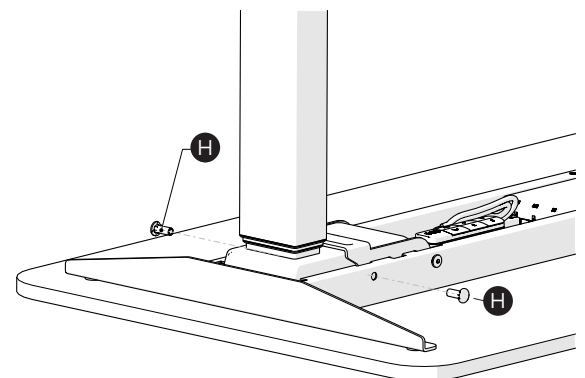

Step 5

Attach the feet **D** to the 4 bolts at the end of each Leg Column. Position the feet so the keyhole slot is around the Column bolts.

Tighten each bolt, ensuring the foot doesn't move out of position.

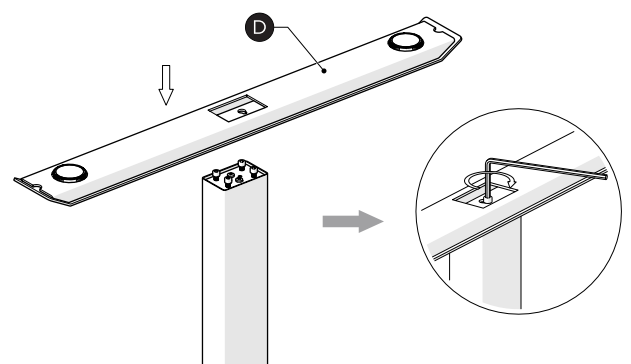

Step 6

Mount the Top Frame and End Pipe to the table top with ST4.8x19 screws **I**.

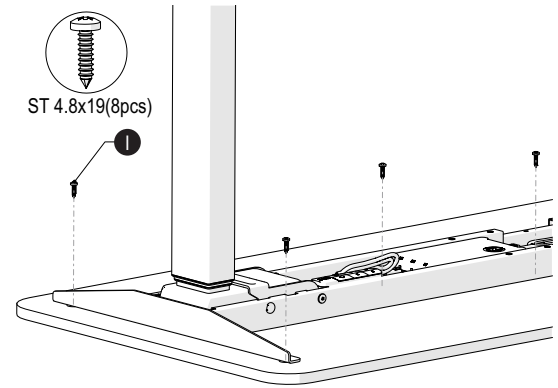

Step 7

Loosen the Handset cable and connect the Handset **G** to the preferred side, using the ST3.5x16mm screws **J**. Tidy excess cable using Cable Clip **L**, if required.

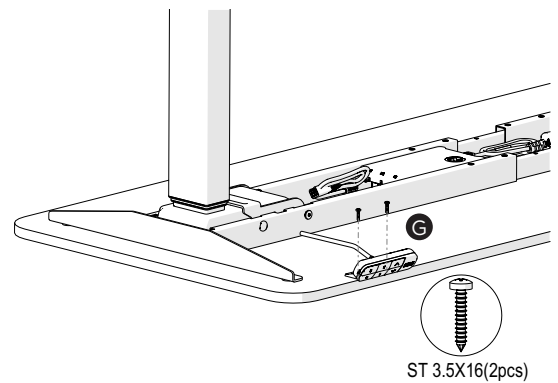

Step 8

Loosen the Connection Cable **F** and Power Cord **E**. Connect the furthest Leg Column **A** from the Control Box to the Connection Cable **F**. Ensure second Column **A**, Power Cord **E**, and Handset **G**, are connected to the control box as shown. Tidy excess cabling.

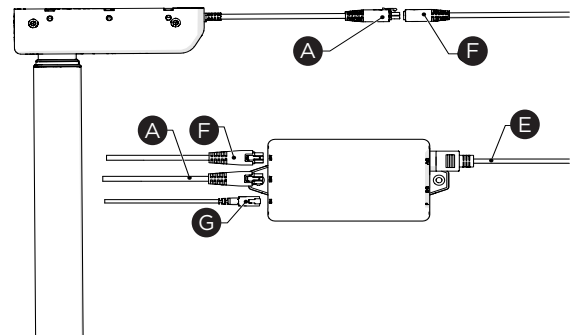

1. Zero Setting

When turning on the desk for the first time, the handset will flash 000 and will not raise. The desk must be lowered to its lowest height before operating. This is called a 'Zero Setting'. Follow these steps:

- Press "Down" button and keep pressing the button until the desktop has reached the lowest position (programmed desktop position).
- Press "Down" button again and hold. After about five seconds, the desktop will slowly move further down until it reaches the lowest possible desktop position.
- Release "Down" button. The electric height adjustable desk is now ready for use.

 Zero setting position is approximate 5mm lower than original starting height position.

2. General Operation

This function enables you to adjust the desk upwards or downwards.

Press "Up" or "Down" button and keep pressing the button until the required frame height is reached.



The desk will continue moving upwards or downwards until you release the button or the maximum / minimum height is reached.

3. Container and Shelf Stop position

These two features can be used to limit the movement area of the desktop (e.g. if a container is placed underneath the desktop). A container stop position can be defined in the lower half of the movement area, a shelf stop position in the upper half. If a container stop position is set, this position will be the lower limit position. If a shelf stop position is set, this position will be the new upper limit position.

To store a container stop / shelf stop position, go on as shown below:

- Move the frame to the position where the container stop / shelf stop position shall be stored. Do so by pressing the "Up" or "Down" until you reach the desired position.
- Press both up and down button ("Up" & "Down") for 5 seconds, you will hear the buzzer sound when the container stop / shelf stop position is stored.



A container stop position can only be stored in the lower half of the movement area and a shelf stop in the upper half.

These steps have to be done for a container stop and a shelf stop position separately!

To remove the container stop/ shelf stop position follow the instructions below:

- Move the desk to any position in the lower half to deactivate the container stop. Move the desk to any position in the upper half to deactivate the shelf stop. Do so by pressing the "Up" & "Down" button until you reach the desired position.
- Press both up and down button ("Up" & "Down") for 5 seconds, you will hear the buzzer sound when the container stop / shelf stop position is deactivated.

These steps have to be done for a container stop and a shelf stop position separately!

4. Reset control box to factory settings

Follow the instructions below to use a configured control box on another identical electric height adjustable desk or to reset the control box to its original factory settings.

- Press the ("Up" & "Down") button and hold for ten seconds.
- The handset makes a buzz at 5 seconds, and then a long beeping sound at 10 seconds. Screen will now flash 000 and will only lower, not raise, as per the original Zero Setting.
- Press the "Down" button until it reaches the lowest possible desktop position. The control box has now been reset to the original factory settings.



If one or more motors are changed in a system, the control box must be reset to factory settings.

5. Lock Setting

It enables you to lock and unlock the handset. To do so follow these steps:

- Press "S" and "up" button and hold until the handset shows "Loc" when the lock setting is complete.
- To remove the lock setting, press "S" and "down" button and hold until a height reappears on screen of the handset.



This function can be used as child lock.

6. Memory Setting

This function allows you to move the desk to a preset position. Follow the instruction steps:

- Move the desk to a desired position and press “S” button until the handset shows “S-” and “-” is flashing.
- Press the number buttons (1, 2 or 3) to set the position as Memory Setting.
- Repeat the above steps to remember up to three positions.



All memory settings will be erased after performing a factory reset.

7. Programs

You can refer to the ‘Appendix: Programs’ to select and save settings, do so by following the steps below.

- Press “S” button and hold for five seconds, the handset will show the parameter “S-x” and “x” will flash.
- Press “up” or “down” button to select the parameter S-1 to S-8 and then press “S” button to save the setting.
- Press “up” or “down” button to adjust the corresponding specification 0-8 and then press the “S” button to save the setting.



All program settings will be reverted to their original factory settings after performing a factory reset.

Appendix: Programs

- S-1: Switch cm or inch display unit.
 - “0” means display with “cm”.
 - “1” means display with “inch”.
- S-2: Balance Protection with sensitivity range options when the front-side and back-side of the tabletop are unbalanced.
 - “0” means close this function.
 - “1” means least sensitive.
 - “8” means most sensitive.
- S-3: Anti-collision Protection with sensitivity range options for desk move up.
 - “0” means close this function.
 - “1” means least sensitive.
 - “8” means most sensitive.
- S-4: Anti-collision Protection with sensitivity range options for desk move down.
 - “0” means close this function.
 - “1” means least sensitive.
 - “8” means most sensitive.
- S-5: Adjust the actual minimum height if the actual height changes, e.g. if the tabletop is raised by 20mm when using the castor.
- S-6: Switch the One-Touch & Constant-Touch memory program.
 - “0” means Constant-Touch.
 - “1” means One-Touch.
- S-7: Duty cycle
 - “0” means off.
 - “1” means on.
- S-8: Balance Protection with sensitivity range options when the left-side and right-side of the tabletop are unbalanced.
 - “0” means close this function.
 - “1” means least sensitive.
 - “8” means most sensitive.

Appendix: Factory Default Settings Matrix

Setting	Default value	Represents
S-1	0	Non-USA market, display set to "cm" by default
S-1	1	USA market, display set to "inch" by default
S-2	6	Balance protection sensitivity level for the front-side and back-side of the desk is set to 6 by default
S-3	6	Anti-collision protection sensitivity level for desk movement upwards is set to 6 by default
S-4	6	Anti-collision protection sensitivity level for desk movement downwards is set to 6 by default
S-5	Different standards	Default position (the lowest height above ground) is in different scenarios
S-6	0	Constant-Touch memory program by default
S-7	1	Duty cycle is activated by default
S-8	6	Balance protection sensitivity level for the left-side and right-side of the desk is set to 6 by default

Appendix: Functions Illustrations

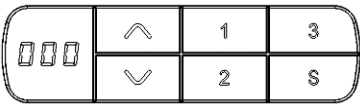
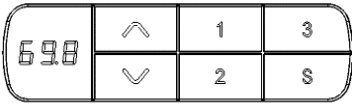
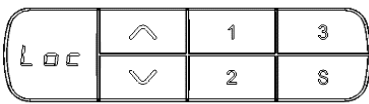
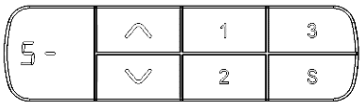
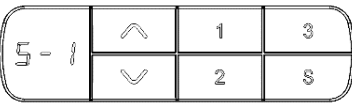
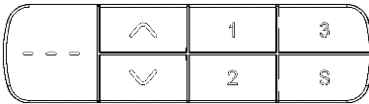
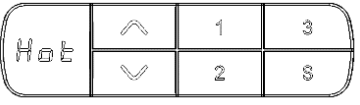
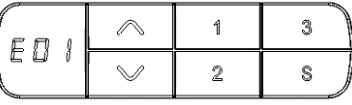
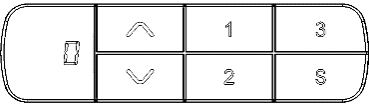
<p>1 000</p> 	<p>2 Lowest position*</p>  <p><small>*Height might be different for different market.</small></p>	<p>3 LOC</p> 
<p>4 S-</p> 	<p>5 S-1 - S-8</p> 	<p>6 --- (Anti-Collision)</p> 
<p>7 HOT</p> 	<p>8 E01-E08</p> 	<p>9 0-8</p> 

Appendix: Troubleshooting of Handset

Error Code	Possible Cause	How to handle it
E01	The main supply voltage is over 45V	Replace the control box
E02	The height deviation between the legs exceeds 1cm	Zero Setting
S-2	Handset connecting or communication error	Check the handset plug
---	Anti-Collision Protection	Wait 2 seconds and re-run
E06	Main power start failed	Replace the control box
E07	Protection when the main power supply is running lower than 20V	Re-plug the power
E08	Tilt when the desktop is running	Zero Setting
HOT	Run over 2 minutes in 20 minutes	Wait 18 minutes and re-run
E11/E12/E13/ E14	Leg for M1 port malfunction	Check all plugs
E15	Leg for M1 port internal short circuit	Replace the leg
E16	Leg for M1 port locked rotor	Zero Setting
E17	Leg for M1 port wrong operation direction	Replace the leg
E18	Leg for M1 port overload	Reduce load
E21/E22/E23/ E24	Leg for M2 port malfunction	Check all plugs
E25	Leg for M2 port internal short circuit	Replace the leg
E26	Leg for M2 port locked rotor	Zero Setting
E27	Leg for M2 port wrong operation direction	Replace the leg
E28	Leg for M2 port overload	Reduce load
E31/ E32 /E33 / E34	Leg for M3 port malfunction	Check all plugs
E35	Leg for M3 port internal short circuit	Replace the leg
E36	Leg for M3 port locked rotor	Zero Setting
E37	Leg for M3 port wrong operation direction	Replace the leg
E38	Leg for M3 port overload	Reduce load
E40	Cascading cable is offline	Check the cascading cable
E41	Memory chip error	Check the cascading cable
E42	Sensor chip error	Replace the control box
E43	Sensor chip error	Replace the control box